

# Annual Report

2012

# 60

FROM SIXTY TO ETERNITY

**GulAhmed**  
TEXTILE MILLS LIMITED, KARACHI

Plot No. 82, Main National Highway  
Landhi, Karachi - 75120 - Pakistan  
UAN: (+92-21) 111-486-486  
finance@gulahmed.com  
www.gulahmed.com









# V

## VALUES

- Integrity
- Passion
- Creativity
- Teamwork



# V

## VISION

Setting trends globally in the textile industry. Responsibly delivering products and services to our partners



# M

## MISSION

To deliver value to our partners through innovative technology and teamwork. Fulfilling our social and environmental responsibilities



# Contents

## Gul Ahmed Textile Mills Limited

Company information	02
The decade of dreams	04
The decade of developments	06
The decade of change	08
The demanding decade	10
The decade of dedication	12
A decade well deserved	14
Code of conduct and ethics	15
Shareholders' information	16
Notice of meeting	17
Directors' report	19
Sustainability Report	23
Financial highlights	25
Our value addition and its distribution	28
Horizontal analysis of financial statements	29
Vertical analysis of financial statements	30
Statement of compliance with the code of corporate governance	31
Review report to the members on statement of compliance with best practices of the code of corporate governance	33
Auditors' report to the members	34
Balance sheet	35
Profit and loss account	37
Statement of comprehensive income	38
Cash flow statement	39
Statement of changes in equity	41
Notes to the accounts	42
Attendance at board meetings	78
Pattern of shareholding	79
<b>Consolidated Financial Statements</b>	
Group Directors' Report	81
Auditors' report to the members	82
Balance sheet	83
Profit and loss account	85
Statement of comprehensive income	86
Cash flow statement	87
Statement of changes in equity	89
Notes to the accounts	90

Form of Proxy

# Company Information

<b>BOARD OF DIRECTORS</b>	BASHIR ALI MOHOMMED ZAIN BASHIR ZIAD BASHIR MOHAMMED ZAKI BASHIR ABDUL AZIZ YOUSUF S.M. NADIM SHAFIQULLAH ABDUL RAZAK BRAMCHARI DR. AMJAD WAHEED ADNAN AFRIDI	- Chairman & Chief Executive - Non Executive Director - Executive Director - Executive Director - Executive Director - Independent Non Executive Director - Non Executive Director - Independent Non Executive Director - Independent Non Executive Director
<b>CHIEF FINANCIAL OFFICER</b>	MOHAMMED SALEEM SATTAR	
<b>COMPANY SECRETARY</b>	MOHAMMED SALIM GHAFAR	
<b>AUDIT COMMITTEE</b>	S.M. NADIM SHAFIQULLAH ZAIN BASHIR MOHAMMED ZAKI BASHIR ABDUL AZIZ YOUSUF	- Chairman & Member - Member - Member - Secretary
<b>HUMAN RESOURCE AND REMUNERATION COMMITTEE</b>	ZAIN BASHIR S.M. NADIM SHAFIQULLAH ABDUL AZIZ YOUSUF	- Member - Member - Member
<b>BANKERS</b>	ALLIED BANK LIMITED BANK AL HABIB LIMITED BARCLAYS BANK PLC PAKISTAN BANK ALFALAH LIMITED - ISLAMIC BANKING BANKISLAMI PAKISTAN LIMITED BURJ BANK LIMITED CITIBANK N.A. DUBAI ISLAMIC BANK PAKISTAN LIMITED FAYSAL BANK LIMITED HABIB BANK LIMITED HABIB METROPOLITAN BANK LIMITED HSBC BANK MIDDLE EAST LIMITED MCB BANK LIMITED MEEZAN BANK LIMITED NATIONAL BANK OF PAKISTAN NIB BANK LIMITED SAMBA BANK LIMITED SILKBANK LIMITED STANDARD CHARTERED BANK (PAKISTAN) LIMITED UNITED BANK LIMITED	
<b>AUDITORS</b>	HYDER BHIMJI & CO. Chartered Accountants	
<b>INTERNAL AUDITORS</b>	ANJUM ASIM SHAHID RAHMAN Chartered Accountants	
<b>LEGAL ADVISORS</b>	A.K. BROHI & CO. ADVOCATES	
<b>REGISTERED OFFICE</b>	PLOT NO. 82 MAIN NATIONAL HIGHWAY LANDHI, KARACHI-75120	
<b>SHARE REGISTRAR</b>	FAMCO ASSOCIATES (PRIVATE) LIMITED 1ST FLOOR, STATE LIFE BUILDING NO. 1-A OFF: II. CHUNDRIGAR ROAD, KARACHI-74000 PHONE NO. (021)32427012, 32426597 & 32425467 FAX NO. (021)32426752	
<b>MILLS</b>	LANDHI INDUSTRIAL AREA KARACHI-75120	
<b>E-MAIL</b>	finance@gulahmed.com	
<b>URL</b>	www.gulahmed.com	



**GUL AHMED TEXTILE MILLS LTD. KARACHI**

**SILVER YARN**

**GTM**  
TRADE MARK

**SILVER COTTON BRAND**

MADE IN PAKISTAN

Cable: "ABADMILLS"  
MOMIN MANZIL, JODIA BAZAR, KARACHI-2

گل احمد ٹیکسٹائل بلومینٹیلڈ - کراچی

एल अहमद टेक्सटाइल मिल्स लि. कराची



1953 - 1962

**THE DECADE OF DREAMS**  
Sometimes, all it takes is a dream.  
Haji Ali Mohammad wished to build a textile empire that would revolutionize the Pakistani industry.  
Gul Ahmed Textile Mills Limited was established with a capacity of 25,000 spindles and 500 looms.  
The dream became a reality.





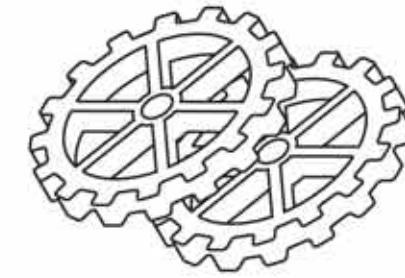

1963 - 1972

#### THE DECADE OF DEVELOPMENTS

As the industrial era dawned upon the nation, the need of the hour was innovation. A state-of-the-art processing mill equipped with hand printing table machines and a continuous Rope Bleaching Range were introduced to the Gul Ahmed facility. Lawn and Chairman Latha were churned out for the Pakistani consumer for the very first time and we at Gul Ahmed wondered, "Have we made the nation happy?"



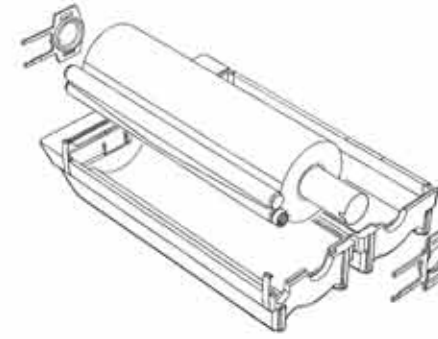

1973 - 1982

THE DECADE OF CHANGE

This decade brought us closer to our people, whose lives we had touched through our rich and diverse fabrics. Gul Ahmed got listed on the stock exchanges of the country's largest and busiest cities; Karachi and Lahore. The first Rotary Printing Machine was installed and Gul Ahmed fabrics were made available on large scale while maintaining the highest quality standards. Gul Ahmed Lawn and Chairman Latha became household names.



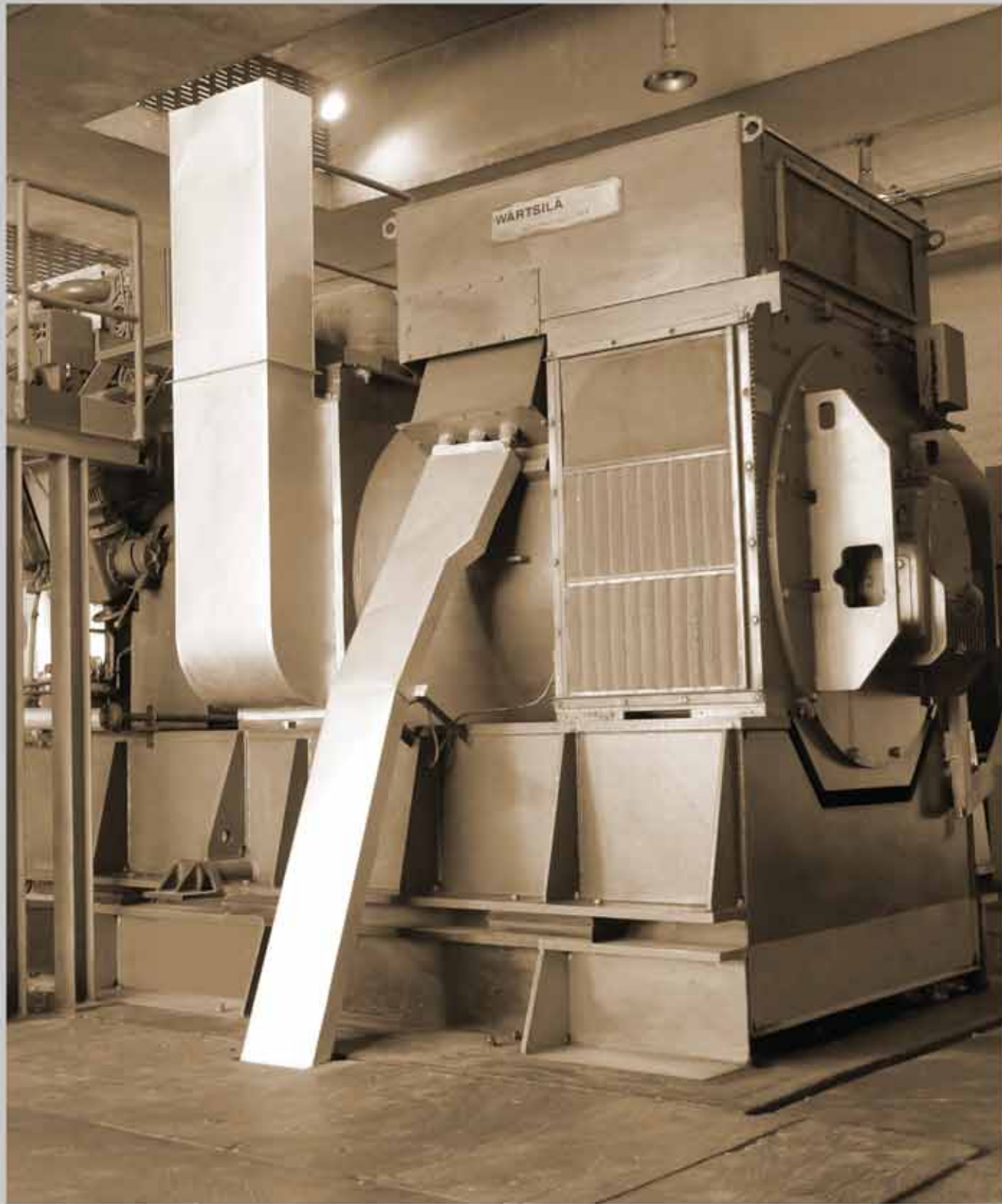

1983 - 1992

THE DEMANDING DECADE  
By now, a lot was happening  
within the walls of Gul Ahmed  
Textile Mills Limited.

From installation of an oil based  
Captive Power Plant to our first  
wider width Rotary Printing  
Machine, our ambitions kept us  
very busy. We stepped into the  
home textile market, participated  
in Heimtex for the first time and  
through relentless hard work,  
touched the billion rupee mark.

We were on a roll!





1993 - 2002

#### THE DECADE OF DEDICATION

The world was moving towards being "tech-savvy", so was Gul Ahmed. The installation of the first fully electronic automatic wider width Air Jet Looms, 21 colour Rotary Printing Machines, a modern laboratory and much more made us the most state-of-the-art mill of the nation. Another world-class idea lit into our minds and our retail stores by the name of "Ideas" popped-up in the major shopping centres of the nation.





2003 - 2012

**A DECADE WELL DESERVED**

Hard work has paid off and that too, generously. In 2007, Gul Ahmed was bestowed the prestigious Superbrands award. Our turnover crossed the gigantic 25 billion rupee mark in 2011. We are the first mill to register and auction carbon credits. We installed caustic recovery units and bagged the Best Corporate Reporting Award. It is due to this vision that our Chairman and Chief Executive of the Company, **Bashir Ali Mohommed** was awarded **Sitare-e-Imtiaz** by the President of Pakistan.

We continue to dream and together with our customers and stakeholders, we will turn these dreams into reality.